

# -10°C~-25°C Biomedical Freezer

Double Compressors • Independent Control



## DW-YL450

### Refrigeration System

- The environmentally friendly Freon-free refrigerant and high-efficiency enclosed compressor supplied by a famous brand can ensure energy saving and low noise.
- The condenser installed on the bottom ensures temperature stability and system reliability.

### Temperature Control

The high-precision computerized temperature control system ensures an adjustable temperature within a range from -10 to -25°C inside the cabinet.

### Security System

The well-developed audible & visual alarm system (sensor failure alarm, high temperature/low temperature alarm, etc.) makes it safer for storage;  
The turn-on delay and stopping interval protection function can ensure reliability in running;

### Human-oriented

The built-in door gasket is dustproof and easy to clean





### High-precision Temperature Control

- The digital temperature display can indicate operating status clearly;
- The high-precision microcomputer temperature control system enables users to set the temperature inside the cabinet within a range from -10°C to -25°C.



### Temperature Ddata Storage

Standard with micro-printer, the minimum storage interval is 1 minute and the maximum storage interval is 240 minutes. It can record 100,000 sets of data, records before more than 100,000 sets of data are automatically overwritten.



### Refrigeration System

- The environmentally friendly Freon-free refrigerant and high-efficiency enclosed compressor supplied by a famous brand can ensure energy saving and low noise;
- The condenser installed on the bottom ensures temperature stability and system reliability;
- The CFC-free polyurethane foam technology and the thicker insulating layer can improve the effect of thermal insulation.

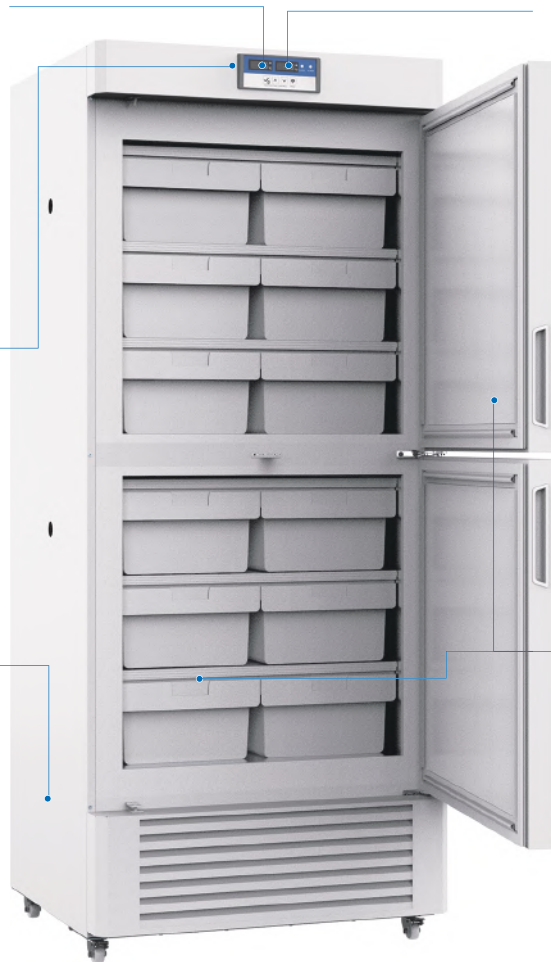

### Alarm system

- The well-developed audible & visual alarm system makes it safer for storage;
- Equipped with alarm functions including high/low temperature alarm, sensor error alarm, power failure alarm, condenser high alarm, low battery alarm, door ajar alarm, grapher failure alarm.
- The turn-on delay and stopping interval protection function can ensure reliability in running;
- The door is equipped with a lock, improving security of sample storage.



### Human-oriented

- The arc angle-shaped door frame and cabinet design makes its appearance more attractive;
- The built-in door gasket is dustproof and easy to clean;
- Each of the refrigerating chamber and the freezing chamber is equipped with 6 drawers, which are convenient for storage of samples.

## ✓ Scope of Application

Suitable for freezing of ice bars and storage of various things needing refrigerated storage such as blood plasma, reagent, etc. Suitable for use in hospitals, clinics, health and disease prevention systems, blood banks, laboratories in colleges & universities, the frozen food industry and catering industry, etc.

## 🔗 Performance Data / Cooling Curve

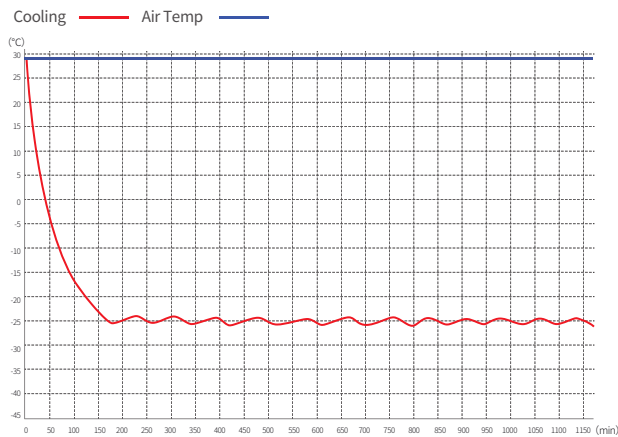

## 📏 Eternal Dimension

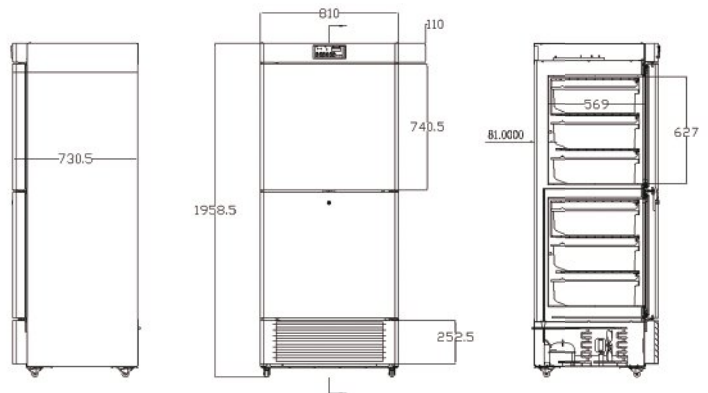

## Specification Chart

-25°C Biomedical Freezer	
Model	DW-YL450
Cabinet Type	Upright
Capacity(L)	450
Internal Size(W*D*H)mm	(650*570*627)*2
External Size(W*D*H)mm	810*735*1960
Package Size(W*D*H)mm	895*820*2035
NW/GW(Kgs)	136/148
Performance	
Temperature Range	-10~-25°C
Ambient Temperature	16-32°C
Cooling Performance	-25°C
Climate Class	N
Controller	Microprocessor
Display	Digital display
Refrigeration	
Compressor	2pcs
Cooling Method	Direct cooling
Defrost Mode	Manual
Refrigerant	R600a
Insulation Thickness(mm)	80
Construction	
External Material	Powder coated material
Inner Material	Aluminum plate with spraying
Drawer	6*2(ABS)
Door Lock with Key	Yes
Door	2
Access Port	2pcs. Ø 25 mm
Casters	4(2 caster with brake)
Data Logging/Interval/Recording Time	USB/Record every 10 minute / 2 years
Backup Battery	Yes
Alarm	
Temperature	High/Low temperature,High ambient temperature
Electrical	Power failure,Low battery
System	Sensor error, USB datalog failure,Condenser high,Door ajar Main board communication error,
Electrical	
Power Supply(V/HZ)	220-240~/50
Rated Power(W)	206
Input Power(W)	340
Power Consumption(KWh/24h)	2.24
Rated Current(A)	1.9
Options Accessory	
System	Printer,RS485, RS232,Remote alarm contact

\*The model, parameters and performance specified in this brochure may be changed without prior notice because of product upgrading.

\*There may be differences between the product images shown in this brochure and the actual products. When you are buying any product, please check the actual product.