

InTemp®

Monitoring Solutions

CX400 Series

Advantages

- Fully-integrated solution for monitoring temperature-sensitive products
- Easy-to-read display with current and daily min/max temperatures
- Audible and visual alarms notify you of an excursion
- Loggers integrate with mobile and cloud platforms for a 21CFR Part 11 compliant solution
- Fast logger setup and download on your mobile device – no need to handle the logger
- Battery-powered to guard against local power loss
- Meets GDP requirements for NIST traceable calibration



InTemp CX400 Monitoring Solutions

Effortless temperature-controlled storage monitoring and compliance

The InTemp CX400 Series is a family of high-performance data loggers for monitoring temperatures in refrigerators, freezers, and other temperature-controlled environments.

Designed to simplify compliance with GDP guidelines for storage temperature monitoring in the pharmaceutical supply chain, InTemp loggers dramatically simplify your process by streamlining daily temperature checks. Leveraging Bluetooth communication from today's mobile devices and the convenience of an app, logger setup and readout times are fast and easy.

Models are available for monitoring ambient temperature in warehouses and cold rooms; probe models for use in refrigerators and freezers.

ONSET®

Technical Specifications

Part number	CX402	CX403
Memory	35,000 measurements	
Logging Rate	User customizable intervals and thresholds via InTemp App	
Probe (external)	Detachable 2 or 4 meter flat ribbon cable with or without an integrated 5, 15, or 30 ml bottle glycol buffer solution Range: -40° to 100° C (-40° to 212° F) Accuracy +/- 0.5° C from 0° to 50° C (+/- 0.9° F from 32° to 122° F)	N/A
Ambient (internal)	Internal Sensor Range: -30° to 70° C (-22° to 158° F) Accuracy: +/- 0.5° C from 0° to 50° C (+/- 0.9° F from 32° to 122° F)	
Bluetooth Compatibility	Wireless protocol: Bluetooth Low Energy, Bluetooth Smart, 4.0 Transmission range: 30.48 m (100 ft) line-of-sight	
Alarms	Visual LED & audible	
Software	InTemp® app: free download from iTunes App Store or Google Play Store	
Power	Battery Type: two AAA 1.5 V alkaline batteries, user replaceable Battery Life: 1 year typical	
Ratings	Certifications: CE, FCC, Environmental: IP54	
Mobile Device Compatibility	iOS 8.3, 8.4, 9.0, 9.1, 9.2 / Android 4.4, 5.0, 5.1 or 6.0.1	

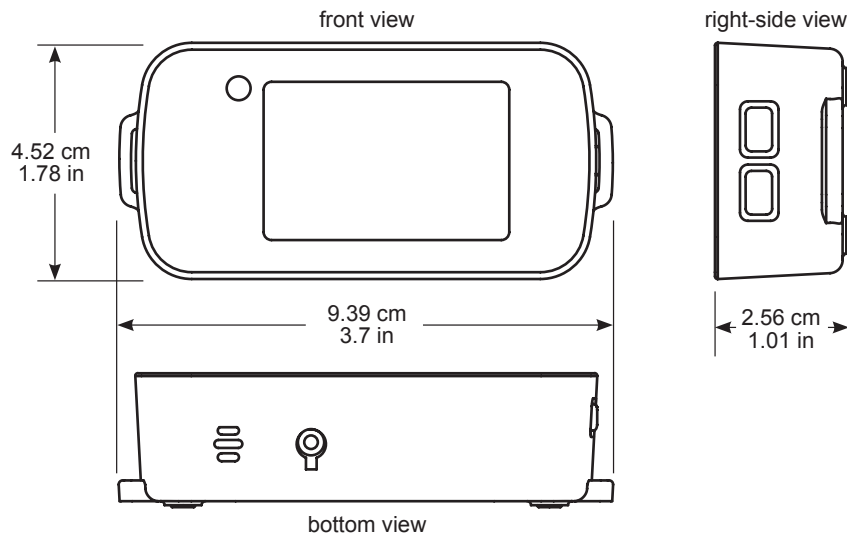

Contact

Email Jamie_Pearce@onsetcomp.com
 Call 1-508-743-3361
 In U.S. toll free 1-800-564-4377
 Fax 1-508-759-9100

ONSET®

Onset Computer Corporation
 470 MacArthur Boulevard
 Bourne, MA 02532